

**TBoat10 Series
UNMANNED SURFACE VEHICLE**

TOKNAV
www.toknav.cn



USER GUIDE

Contents

1. Overview -----	03
1.1 Control Console-----	03
1.2 Motor Kit -----	03
1.3 Receiver Kit -----	04
1.4 Others-----	06
2. Equipment Installation -----	09
2.1 Tablet -----	09
2.2 Motor -----	09
2.3 Receiver-----	10
3. Software Introduction -----	11
3.1 Open the Software -----	11
3.2 Icons-----	12
3.3 Icons In Settings-----	13
3.4 Registration -----	14
3.5 Base Station Settings -----	16
3.6 Vehicle Parameter Settings-----	17
3.7 Farm Tool Parameter Settings -----	19
4. Water Quality Monitoring & Sampling Solutions-----	21
4.1 Water Quality Sampling Equipment-----	21
4.2 Water Quality Monitoring Equipment -----	24
4.3 USV Water Quality Monitoring and Sampling Workflow-----	27

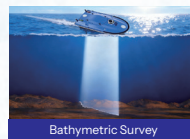
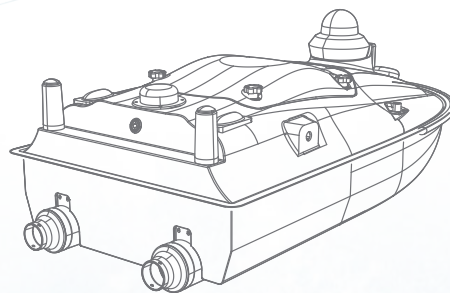

Bathymetric Survey



Water Quality Monitoring



Tboat10-A



Tboat10-B



Water Quality Sampling



Patrol USV with Side-scan sonar



Tboat10-C



Tboat10-D

1. Overview

1.1 Introduction to Unmanned Surface Vehicle

Tboat10 Unmanned Surface Vehicle (USV) is built on a fully modular, plug-and-play architecture.

The vehicle integrates seven line-replaceable modules—hull shell, mission-control core, propulsion unit, collision-avoidance suite, high-precision positioning package, wireless telemetry link, and hot-swappable power pack—into a single, watertight assembly.

The shore-side segment is a single Android-based, long-range telemetry controller that unifies differential corrections uplink, real-time data downlink and remote control.

All onboard and post-mission workflows are handled by Hydroscan, an integrated vessel-control and hydrographic-processing application.

Detailed functional descriptions of each hardware unit and software module are provided in the following sections.

1.2 Hull and Hardware Architecture

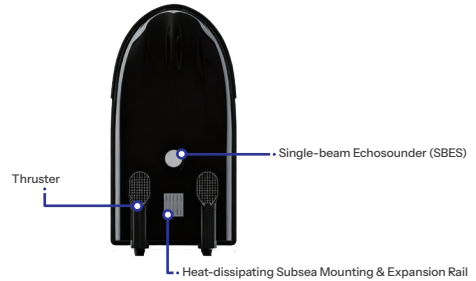
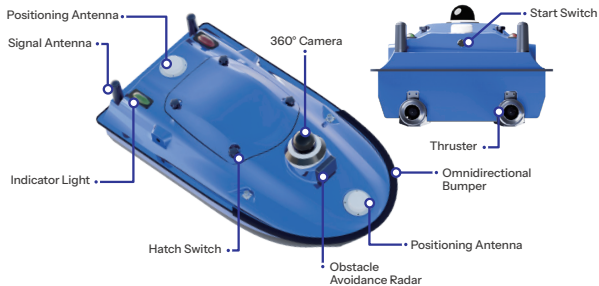

1.3 Heat-dissipating Subsea Mounting & Expansion Rail

(1) The Remote Controller is built around a 6 nm, octa-core Qualcomm SoC running Android 13 (64-bit). A high-power 2.4 GHz / 5.8 GHz dual-band radio module delivers low-latency, high-definition video with extended range and robust interference rejection.

(2) A built-in 7-inch high-brightness HD panel (1920 × 1200) provides real-time video feedback from the survey payload. Dual internal fans maintain thermal stability for continuous field operation.

(3) Interfaces include SIM card, USB and Type-C ports for differential corrections uplink, data logging and peripheral expansion.

(4) A high-energy-density Li-ion pack gives 6–8 h of autonomous runtime per charge.

(5) It is made of meteorological silicone, matte rubber, and ABS material. The G20 has taken dust-proof protection

measures on the body, control switches, and all peripheral interfaces to ensure stable and smooth operation in harsh environments.



Controller Specifications

1	Channels	16
2	Operating voltage	4.2 V (internal battery)
3	RF power	23 dBm @CE/FCC
4	Band	2.4 GHz
5	Dynamic FHSS	hopping enabled
6	Dimensions	277 mm (L)×138 mm (W)×96 mm (H)
7	Weight	1.2 kg
8	Endurance	6-8 h
9	Battery	20000 mAh
10	Firmware update	OTA / on-line
11	Charge port	TYPE-C
12	RAM	4 GB
13	Internal storage	64 GB

1.4 Controller Operations

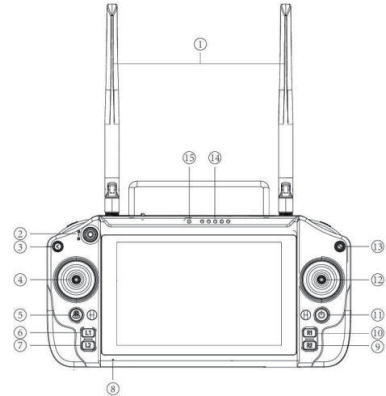

1	2.4 GHz antenna
2	3-position toggle switch (FWD: Auto / MID: Hold / AFT: Manual)
3	Back key
4	Left stick (forward/reverse control)
5	Return-to-home (RTH) key
6	L1 - mission-planning shortcut
7	L2 - safety-settings shortcut
8	Microphone
9	R2 - USV status shortcut
10	R1 - vessel-control parameters shortcut
11	Power key
12	Right stick (port/starboard control)

13	Data-logging stop key
14	Battery Indicator Light
15	Linking Indicator Light

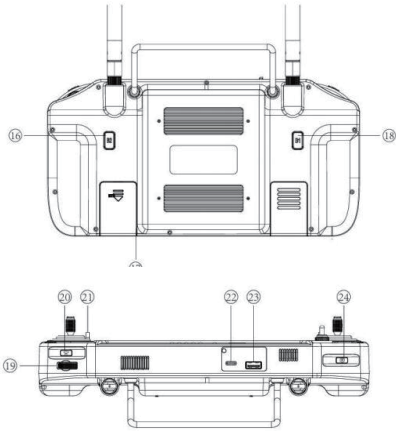

16	B2 key (reserved)
17	TF-card / SIM-card slot
18	B1 key (reserved)
19	Spring-return thumb-wheel for gimbal pan control
20	Camera-view toggle key
21	Lanyard eyelet
22	TYPE-C port
23	USB port
24	Photo-capture key

Operating Environment

- a. Ambient temperature: -10 °C to +45 °C
- b. Storage temperature: -20 °C to +50 °C
- c. Relative humidity: ≤ 85 % RH
- d. Atmospheric pressure: 86 kPa – 106 kPa
- e. Location must be free of explosive, corrosive or electrically conductive media; gases that attack metals or degrade insulation; significant water vapour; and heavy mould growth
- f. Site shall provide protection against rain, snow, wind-blown sand and dust

Power Supply & Safety Notes

- a. The ground station contains an integrated, rechargeable Li-ion battery and can be charged through the market-standard TYPE-C port using any certified USB charger (e.g., phone or camera adapter).
- b. If smoke, odour or electrolyte leakage is observed during charging, discontinue immediately and return the unit to an authorised service centre.
- c. Keep the charging area out of reach of children to prevent electric-shock hazards.
- d. Do not charge at ambient temperatures exceeding 60 °C.

Pre-operation Checks

- a. Verify that the controller battery is adequately charged before use.
- b. Confirm that all antennas are positioned as specified to ensure optimum performance.
- c. Do not operate the unit while under the influence of

alcohol or any impairing substance.

e. Use only certified, professional-grade chargers for the battery.

f. The antennas are fragile—avoid excessive force or impact.

2. Hardware Operation

2.1 Accessory Installation

(1) Install battery → mate aviation power plug → switch battery ON.

(2) Connect main-camera Ethernet and power cables.

(3) Close hatch; tighten thumb-screws.

2.2 Pre-Launch Checks

(1) Power On

USV: Press and hold the stern power button for 3 s until the indicator light blinks rapidly, then release. After around 10 s the light turns solid, indicating the onboard mission computer is fully booted.

Controller: Switch on the Controller, launch the Hydrosan app and connect to the USV via video-link. A solid red LED on the port side of the hull confirms successful link establishment.

(2) Thruster airflow check

Use the stick commands to verify correct blower direction:

Forward (left stick forward): both thrusters exhaust aft.

Reverse (left stick back): no airflow from either thruster.

Port turn (right stick left): port thruster—no airflow; stbd thruster—exhaust aft.

Stbd turn (right stick right): port thruster—exhaust fwd; stbd thruster—no airflow.

(3) Power-on self-test (POST)

After the Hydrosan video-link is established the vessel runs its POST; all items must pass before launch

2.3 Battery Charging Procedure

(1) Charge both the lithium battery pack and the controller only with the supplied dedicated charger.

(2) Mating procedure:

Align and fully seat the charger plug into the battery port first. Then insert the charger mains plug into 220 V AC.

LED logic:

POWER LED only → no battery connected

CHARGE LED red → charging

CHARGE LED green → charge complete; battery ready for use

(3) Battery care

a. New batteries are shipped with ≥ 30 % SOC; bring to 100 % within two months.

b. Recharge immediately when the one-bar (low-battery) indicator appears.

c. A fully-charged battery may be stored for up to six months; recharge again after this period.

3. Software Operations

3.1 Software Overview

Hydroscan is a proprietary, survey-ready control and post-processing suite developed for unmanned surface vehicles. It supports multiple survey modes, enabling unmanned vessels to execute tasks automatically and adapt to various scenarios. The software provides hull control, route planning, status display, safety alerts, and online upgrades; it uses an integrated remote, supports 4G communication and data-link connection, and allows real-time triple-view video display. It supports external sensors, whose data can be integrated and shown in the vessel-control app without carrying a computer; post-processing overlays water-depth waveforms, so depth noise points are traceable; multiple data correction modes are offered to ensure accuracy and reliability. From the customer's perspective, the software pursues more accurate measurement, more user-friendly operation, and simpler functions for rapid deployment.

(1) Technical specifications

Operating environment: Android 13.

(2) Installation & removal

Installation: copy the Hydroscan vessel-control package (*.apk) to the local Download folder on the Controller; tap the desktop file icon, open the Download folder, and tap the Hydroscan package to start installation; after successful installation the App icon appears on the desktop.

Uninstall: Long-press the Hydroscan icon, drag it to the uninstall area on the screen, tap "OK" when prompt of uninstalling appears, and the software is removed.

(3) Version check and update

When the app is launched with an active network, it queries the server. If a newer build is available, a pop-up appears with the update details. If the handset is not on Wi-Fi, you will be asked whether to proceed with the download.

The Controller comes with the Hydroscan USV control app pre-installed; if it is missing, please contact the technical support for installation.

Note: many features require a mobile data connection, and network RTK corrections for the vessel are delivered via the Internet—ensure a reliable network is available whenever the system is operated.

3.2 Establishing Connection

(1) Tap the Hydroscan app icon to launch it; on the home screen tap the "Tboat10" button in the lower-right corner to open the USV connection dialog, then select "Video-Link → Connect" or "4G → Connect".

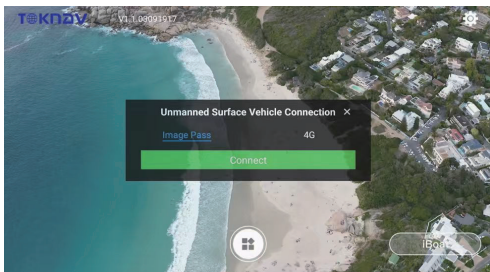

(2) The USV offers two link options—4G and video-link (default: video-link).

In 4G mode the vessel ID is its SN number and the password is “ubinavi2023”.

After successful pairing the button changes to “Disconnect”.

3.3 Project Creation

(1) Go to Task Management to select an existing project or create a new one.

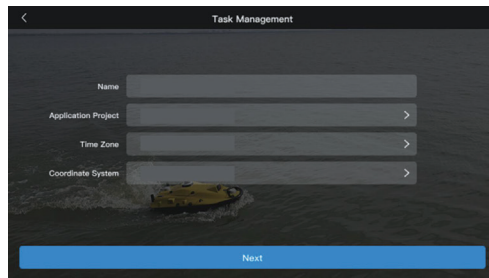
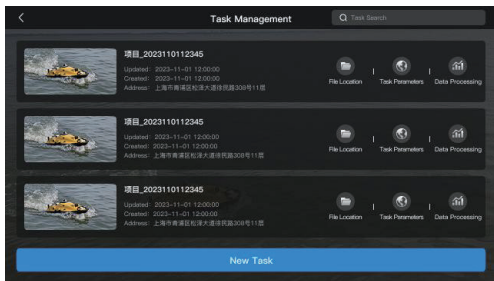

After configuring the project parameters, click [Next] to complete the project setup and enter the vessel control interface.

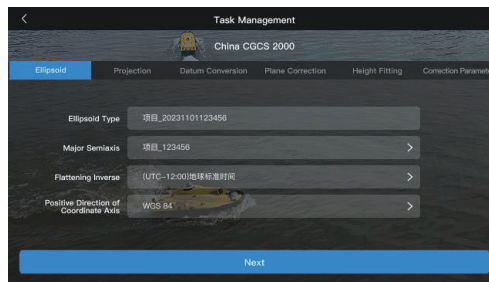

3.4 (USV) Self-Test

(1) When the unmanned vessel is connected, the system will prompt for a startup self-test upon initial entry into the vessel control interface. Click [Confirm] to proceed to the next step.



Vessel Control Interface Status Indicators:

4G Network Signal:

Displays real-time network quality of the unmanned vessel.

1. $\geq 80\%$: Full bars (3 bars)
2. $\geq 60\%$: 2 bars
3. $\geq 40\%$: 1 bar
4. $< 40\%$: 0 bars GNSS Solution Mode:

Positioning status:

5. Single (White)
6. Float (Yellow)
7. Fixed (Green)

Echosounder (Depth Sensor):

8. Normal (Green) if connected successfully; otherwise, Abnormal (Red). Propulsion System:

9. Normal (Green) if connected successfully; otherwise, Abnormal (Red). Camera:

10. Normal (Green) if connected successfully; otherwise, Abnormal (Red). Obstacle Avoidance Module:

11. Normal (Green) if connected successfully; otherwise, Abnormal (Red). Remote Controller:

12. Normal (Green) if connected successfully; otherwise, Abnormal (Red).

Unmanned Vessel Battery:

13. Normal (Green) if connected successfully; otherwise, Abnormal (Red). Battery Level Indicators:

14. $> 50\%$: Green

15. $10\% - 50\%$: Yellow

16. $\leq 10\%$: Red

3.5 Navigation Route Planning

Navigation to Route Planning Interface:

1. Access the vessel control interface, then locate and select the red-highlighted button on the right side.
2. Choose the "Route Planning" function to enter the route planning interface.

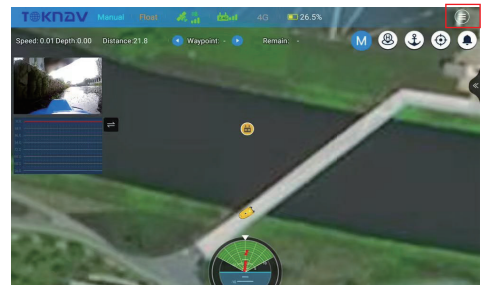

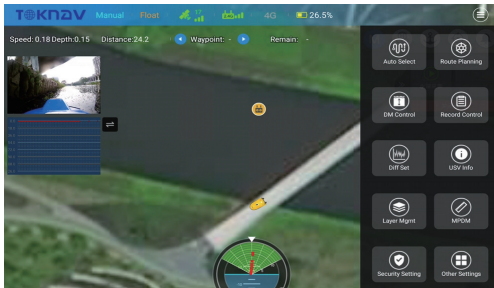

3.6 Manual Route Drawing

1. Select Waypoints:

Click the red-highlighted button to activate selection mode.

On the satellite map, click multiple locations to generate waypoints. The system will automatically determine the navigation path and direction based on the order of clicks.

2. Adjust Waypoint Order:

Use the blue-highlighted bidirectional arrow to swap the sequence of selected waypoints.

3. Delete Waypoints:

Click the yellow-bordered button to remove unwanted waypoints.

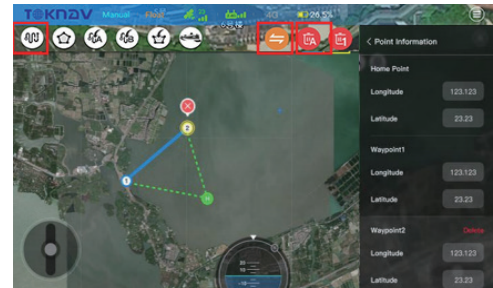

4. Polygon-Based Route Generation Instructions:

Click the red-highlighted button to activate polygon mode.

Single click on the map adds a boundary point. Three clicks generate a triangular polygon; continue clicking to add more vertices.

5. Edit Polygon (Left Panel):

Ensure the "Edit Polygon" button remains selected to: Drag & move the entire polygon.

Delete points: Click a vertex to select it, then press the "Delete Point" button.

6. Generate Route (Right Panel):

Click "Generate Route" to create a default path within the polygon.

Customize routes by adjusting:

Spacing (between parallel tracks)

Angle (route direction)

Buffer (expand/shrink polygon edges)

Start Point (initial waypoint).

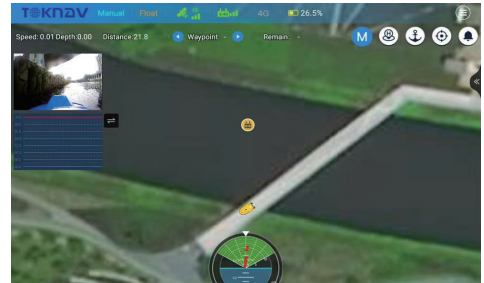
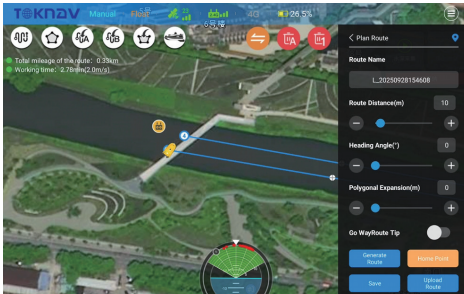

3.7 Video Surveillance

Camera View Operation:

1. Enter Camera View:

Click the camera feed icon (top-left corner) to enter the live video interface.

Supports split-screen display for multitasking.

2. Main Video Feed:

Displays real-time environmental footage from the unmanned vessel's perspective during navigation.

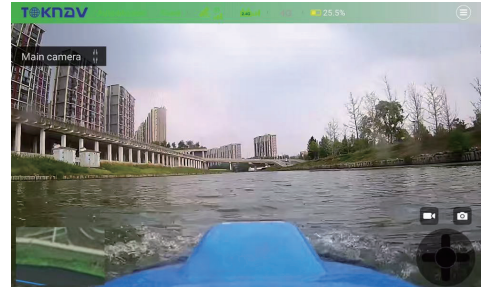

4. Water Quality Monitoring & Sampling Solutions

4.1 Water Quality Sampling Equipment

The USV water sampling system consists of a sampling pump, pinch valves, sampling bottles, electric sampling arm assembly, electric sampling arm, sampling head, and silicone tubing. It supports collection capacities of 100mL, 200mL, 500mL, 1000mL, 1500mL, 2000mL, and 5000mL. It supports configuration of single, dual, 4, 6, or 7 sampling bottles (customizable). The electric sampling arm samples surface water (50cm depth). Functions include remote control sampling via software, auto-route sampling, pipeline rinsing, bottle rinsing, emptying, emergency stop, and sampling data recording.

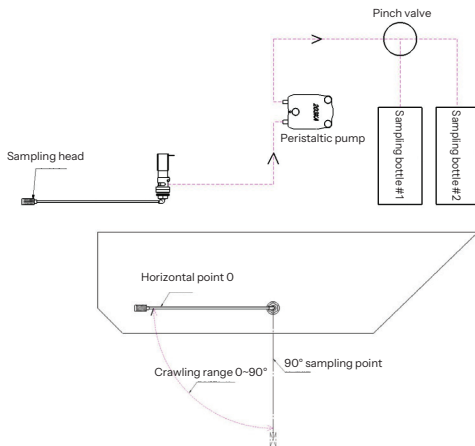

21

Sampling Pump: Utilizes an imported peristaltic pump with long-life tubing. Flow rate: $\geq 500\text{mL}/\text{min}$. Controlled by a stepper motor. Sampling volume error: $\leq 7\%$. Repeatability: $\leq 5\%$.

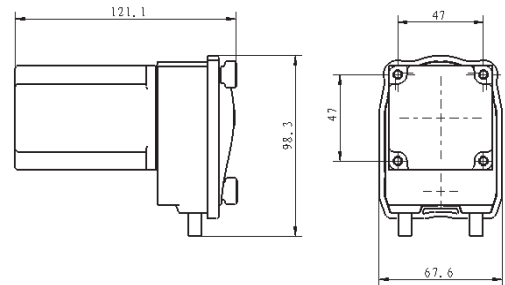

Water Distribution: Uses two-position three-way solenoid pinch valves. This effectively prevents clogging, and since the liquid only passes through the silicone tubing, there is zero cross-contamination of the water sample.

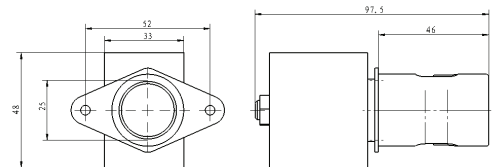

22

Sampling Bottles: Uses 1L Polyethylene or glass bottles (Customizable based on cabin space).

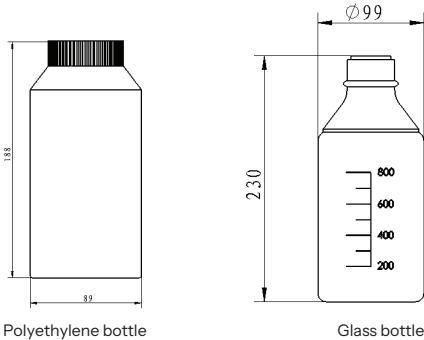

Installation: Sampling bottles are mounted on the side extension bracket. Water samples are collected through operations such as collection, rinsing, and discharge using an electric sampling arm. The hull is equipped with a sampling pump, electrically controlled valves, a sampling control unit, and pipelines.



4.2 Water Quality Monitoring Equipment

Online Multi-parameter Water Quality Sensor: Features an integrated design that is reliable and easy to use. It can measure up to 8 parameters simultaneously. Available sensor types include Dissolved Oxygen (DO), COD, pH, ORP, Conductivity/Salinity, Ammonia Nitrogen, Turbidity, Fluoride, etc. Uses RS-485 bus and Modbus/RTU communication protocol for direct data transmission to the platform.

The sensor is equipped with an automatic cleaning device (wiper) with settable intervals and cycles to adapt to different water conditions. This effectively cleans the sensor surface, preventing microbial attachment and significantly reducing maintenance costs. Each sensor features a quick-release waterproof connector for easy assembly/disassembly. A protective guard surrounds the sensors to prevent damage from large particles or aquatic life without affecting measurement accuracy.



Parameters of Optional Sensors

Dissolved Oxygen Sensor	
Measurement Range	0~20mg/L
Accuracy	±0.4mg/L
Resolution	0.01mg/L

Turbidity Sensor	
Measurement Range and Accuracy	0~100NTU ±3% or ±2NTU 0~1000NTU ±5% or ±3NTU
Resolution	0.1NTU

Conductivity/Salinity Sensor	
Measurement Range and Resolution	0~5000uS/cm 1uS/cm 0~200uS/cm 0.1mS/cm 0~70uS/cm 0.1PSU
Accuracy	±1.5% F.S.

COD Sensor		
Range	COD 0~200mg/L equiv. KHP 0~500mg/L equiv. KHP	Turbidity 0~100NTU 0~200NTU

COD Accuracy	±5%F.S.
COD Resolution	0.1mg/L
Turbidity Accuracy	±5%F.S.
Turbidity Resolution	0.1NTU

pH Sensor	
Range	0~14pH
Accuracy	±0.1pH
Resolution	0.01pH

ORP Sensor	
Range	-1500mV ~ +1500mV
Accuracy	±6mV
Resolution	1mV

Ammonia Nitrogen Sensor	
Range	0~100mg/L or 0~1000mg/L
Accuracy	±10% or ±2mg/L
Resolution	0.1mg/L

Fluoride Ion Sensor	
Range	0~100.00mg/L
Accuracy	±10% of reading or ±1mg/L, ±0.5°C
Resolution	0.01mg/L

Temperature	
Range	0~50°C
Accuracy	±0.5°C
Resolution	0.1°C

Other Information	
Output Method	RS-485(Modbus/RTU)
Cleaning Method	Automatic Cleaning
Power Consumption	5W @ 12V
Power	12VDC±5%
Cable Length	Standard 5 meters (Customizable)

4.3 USV Water Quality Monitoring and Sampling Workflow

Preparation:

Mount the multi-parameter water quality sensor at the stern and connected to the unmanned surface vessel's battery via a cable.



Startup & Check: Launch the "Hydroscan" control software and connect to the USV. Create or select a mission. Enter the control interface and perform an automatic system check (Network signal, GNSS status, Battery level, Motor status, Camera status, Obstacle avoidance module, etc.).

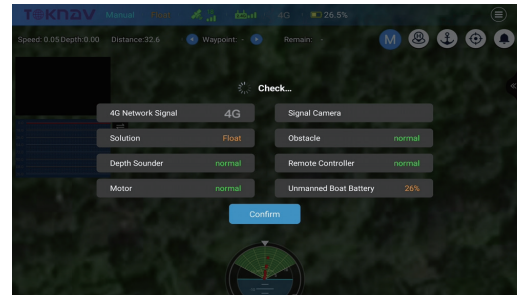
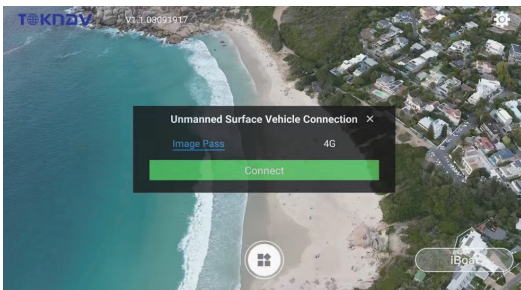

Mission Dispatch: Use the software to plan the route or control the USV manually. Dispatch the mission to the USV. Once in the water, the USV executes the route. Water quality data can be viewed and saved in real-time during navigation.

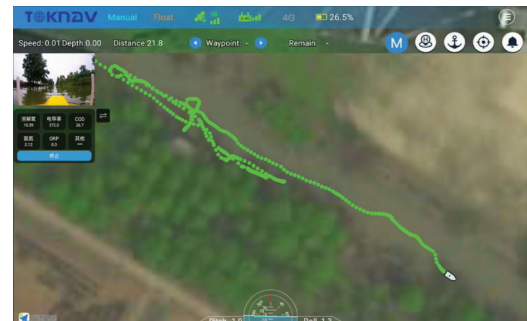

Navigation & Sampling Phase: The USV can be paused or sent to waypoints for sampling at any time. Clicking "Sample" triggers automatic pipeline rinsing. Users can manually control bottle emptying or stop sampling. Detailed sampling information is recorded for each point.



序号	采样编号	采样时间	经纬度	深度	采样量(L)	瓶内液体颜色	采样状态	水质数据
1	1号瓶	2022-10-21-10:59	120724.441°E	30°47'20.443"N	500	清澈	成功	0.0
2	2号瓶	2022-10-21-10:59	120724.441°E	30°47'20.443"N	500	清澈	成功	0.0
3	3号瓶	2022-10-21-10:59	120724.441°E	30°47'20.443"N	500	清澈	成功	0.0
4	4号瓶	2022-10-21-10:59	120724.441°E	30°47'20.443"N	500	清澈	成功	0.0
5	5号瓶	2022-10-21-10:59	120724.441°E	30°47'20.443"N	500	清澈	成功	0.0
6	6号瓶	2022-10-21-10:59	120724.441°E	30°47'20.443"N	500	清澈	成功	0.0
7	7号瓶	2022-10-21-10:59	120724.441°E	30°47'20.443"N	500	清澈	成功	0.0
8	8号瓶	2022-10-21-10:59	120724.441°E	30°47'20.443"N	500	清澈	成功	0.0
9	9号瓶	2022-10-21-10:59	120724.441°E	30°47'20.443"N	500	清澈	成功	0.0
10	10号瓶	2022-10-21-10:59	120724.441°E	30°47'20.443"N	500	清澈	成功	0.0
11	结束						成功	0.0



Completion: After the mission is complete, the USV returns to the dock or shore for the manual retrieval of water samples.